



MANUAL AND USER GUIDE

HEARING HELPER™ Personal FM System Wireless FM Listening System

Models PFM 350, PFM 300, PFM 350E RCH, & PFM 300E RCH
Transmitter Model PFM T32
Optional Receiver Models PFM R32, R31

MAN 072H

HEARING HELPER™ PERSONAL FM SYSTEM MODELS PFM 350, PFM 300, PFM 350E RCH, PFM 300E RCH INSTALLATION GUIDE & USER MANUAL

Contents	Page
SYSTEM OVERVIEW	3
SYSTEM COMPONENTS	4
SAFETY INFORMATION	5
RECYCLING INSTRUCTIONS	5
OPERATING INSTRUCTIONS	
PFM T32 TRANSMITTER	6
PFM R32 RECEIVER	9
PFM R31 RECEIVER	10
BATTERY INFORMATION	
BATTERY INSTALLATION	13
RECHARGEABLE AND NON-RECHARGEABLE BATTERIES	13
USING OPTIONAL CHG 200 BATTERY CHARGER	14
USING YOUR PERSONAL FM SYSTEM WITH A HEARING AID	15
APPLICATIONS FOR VARIOUS HEARING LOSS LEVELS	15
IN CASE OF DIFFICULTY	16
WARRANTY	17
SYSTEM SPECIFICATIONS	18
ACOUSTIC SPECIFICATIONS	19

SYSTEM OVERVIEW

Thank you for purchasing the Hearing Helper™ Personal FM System from Williams Sound Corp. Anyone needing auditory assistance to overcome background noise, reverberation, or distance from the sound source can benefit from the Personal FM System.

Your PFM System has two principal parts: the Transmitter and the Receiver. Much like a miniature radio station, the Transmitter and microphone pick up the sounds you want to hear and broadcast them over an FM radio signal. The receiver and earphone are used to pick up the broadcast up to 100 feet away.

To avoid difficulties, please read through these instructions as you begin to use the system. Then save them for questions that arise as you continue to use your Williams Sound Personal FM System.

If you have problems with the PFM system, don't hesitate to call us toll-free at 1-800-843-3544.

FIGURE 1: HOW THE PFM SYSTEM WORKS

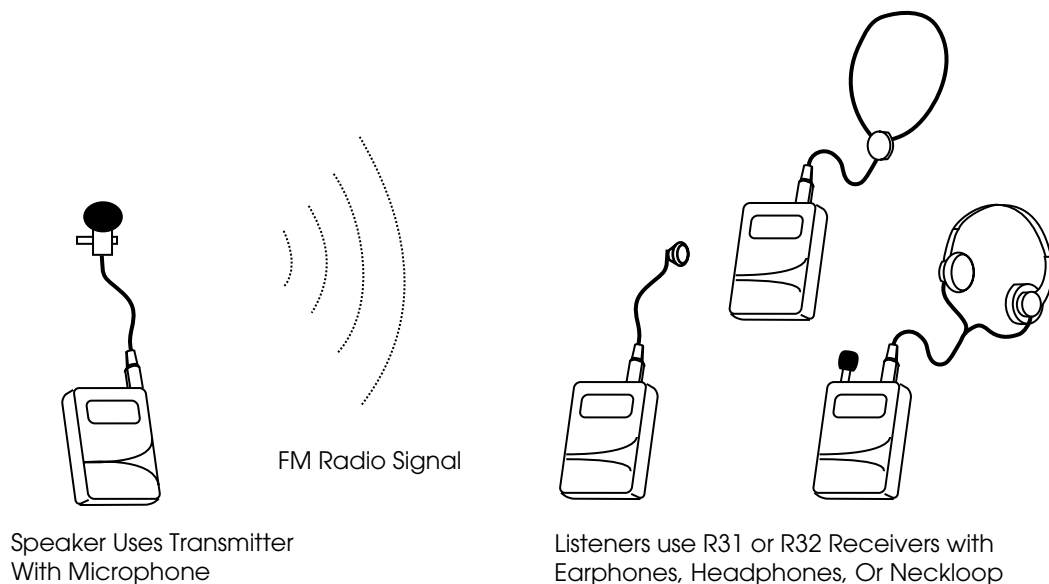

The speaker wears the body-pack transmitter and a clip-on microphone. The speaker's voice is broadcast as an FM radio signal over a distance of 100-150 feet (30-45 m). Listeners use the pocket receiver and earphone or headphone to hear the speaker's voice directly, with reduced background noise. A neckloop telecoil coupler allows the system to be used with telecoil (T-Switch) equipped hearing aids.

SYSTEM COMPONENTS

- ▶ Body Pack Transmitter (PFM T32) with (2) AA batteries (BAT 001)
- ▶ Lavalier microphone (MIC 090)
- ▶ Mini earphone (EAR 013)
- ▶ Soft Nylon System Carry Case (CCS 020)
- ▶ (2) Belt clip cases (CCS 001)
- ▶ Instructions (MAN 072)
- ▶ PFM System 300 Only:
Personal FM Receiver (PFM R32) with (2) AA batteries (BAT 001)
- ▶ PFM System 350 Only:
Personal FM Receiver (PFM R31) with Plug Mount Microphone (MIC 014)
and (2) AA batteries (BAT 001)
- ▶ PFM System 300E RCH Only:
Personal FM Receiver (PFM R32) with CHG 200A Drop-in Charger and (2) AA NiMH
rechargeable batteries (BAT 026)
- ▶ PFM System 350E RCH Only:
Personal FM Receiver (PFM R31) with CHG 200A Drop-in Charger and (2) AA NiMH
rechargeable batteries (BAT 026)

FIGURE 2: SYSTEM COMPONENTS



T32 Transmitter
(PFM 300 & 350 Systems)



R32 Receiver
(PFM 300 System)



R31 Receiver
(PFM 350 System)

SAFETY INFORMATION

HEARING SAFETY



CAUTION!

This product is designed to amplify sounds to a high volume level which could potentially cause hearing damage if used improperly. **To protect your hearing and the hearing of others:**

1. Make sure the volume is turned down before putting on the earphone or headphone before adjusting the volume to a comfortable level.
2. Set the volume level at the minimum setting that you need to hear.
3. If you experience feedback (a squealing or howling sound), reduce the volume setting and move the microphone away from the earphone or headphone.
4. Do not allow children **or other unauthorized persons** to have access to this product.

BATTERY SAFETY AND DISPOSAL



CAUTION!

This product is supplied with disposable Alkaline batteries. Do not attempt to recharge disposable batteries, which may explode, release dangerous chemicals, cause burns, or other serious harm to the user or product.

PACEMAKER SAFETY:



CAUTION!

1. **Before** using this product with a pacemaker or other medical device, consult your physician or the manufacturer of your pacemaker or other medical device.
2. If you have a pacemaker or other medical device, make sure that you are using this product in accordance with safety guidelines established by your physician or the pacemaker manufacturer.

RECYCLING INSTRUCTIONS

BATTERY SAFETY AND DISPOSAL



Help Williams Sound protect the environment! Please take the time to dispose of your equipment properly.

Product Recycling for Customers in the European Union:

Please do NOT dispose of your Williams Sound equipment in the household trash. Please take the equipment to a electronics recycling center; OR return the product to the factory for proper disposal.

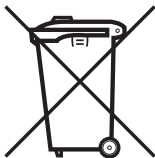

Battery Recycling for Customers in the European Union:

Please do NOT dispose of used batteries in the household trash. Please take the batteries to a retail or community collection point for recycling.

12/27/06

USING THE PFM T32 TRANSMITTER

1. Install two (2) AA batteries. If you're using rechargeable batteries, they must be charged before using. See *battery information* on page 13.
2. Plug the microphone cord into the "Mic" jack on top of the transmitter.

FIGURE 3: T32 TOP VIEW

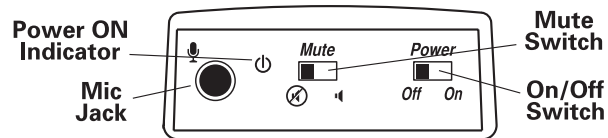

3. Place the transmitter in the belt clip case provided.
4. Slide the Power Switch on top of the transmitter to "On." The Power ON LED indicator should illuminate Red.
5. The microphone should be placed as close to the speaker's mouth as is practical. For lapel mics, attach the microphone to a collar, lapel, or tie.
6. When you are ready to speak, turn the Mic Mute Switch (speaker icon) to the "On" position. When you are done speaking, mute the mic by turning the Mute Switch to the "Off" position (speaker icon with line through it).
The transmitter can be placed in a pants pocket, or clipped onto a belt or waistband.

FIGURE 4: CORRECT MICROPHONE PLACEMENT

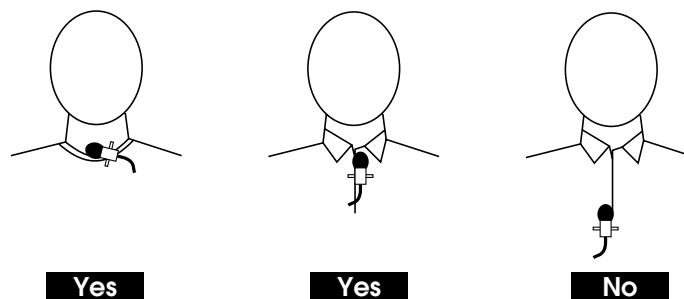

The PFM System comes with an omnidirectional, lapel-clip style microphone. It should be clipped to a collar, lapel, tie, or neckline as close to the mouth as possible and centered on the body as shown.

Note On The Transmitter Antenna:

The microphone cord is the transmitting antenna. Do not bunch up the cord or wrap it around the transmitter. For maximum range, the cord should hang as straight as possible.

CHANGING THE PFM T32 FREQUENCY

FIG. 5: PFM T32 FREQUENCY CHANGE

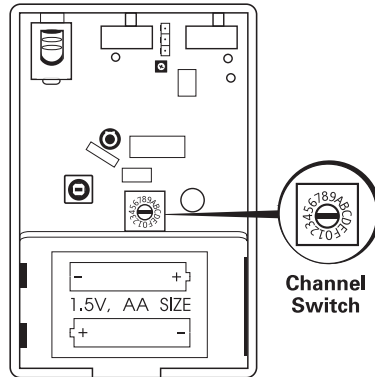

Frequency (MHz)	Switch Position	Wideband Channel
72.1	0	A
72.2	1	K
72.3	2	B
72.4	3	N
72.5	4	C
72.6	5	O
72.7	6	D
72.8	7	P
72.9	8	E
74.7	9	I
75.3	A	J
75.4	B	R
75.5	N/A	F
75.6	C	S
75.7	D	G
75.8	E	T
75.9	F	H

By default, the T32's frequency is set to 72.9 MHz (Channel E). If you experience FM interference, or if you need to match a receiver's frequency, it may be necessary to adjust the frequency on the T32. Instructions:

1. Open the battery compartment using a coin in the slot in the bottom of the transmitter. Remove the batteries.
2. Lift the battery compartment door up and pull to your left to expose the circuit board.
3. Refer to **FIG 5** to locate the Channel Switch.
4. Use a small screwdriver to rotate the Channel Switch to correspond with the desired operating frequency. Choose between 16 standard channels. Refer to the Channel Selection Chart in **FIG 5** for available channels.
5. Reinstall the batteries, then close the back of the transmitter.
6. Plug the microphone in and turn the transmitter on to provide a tuning signal for the receivers.

Important: Make sure all receivers being used match the frequency of the transmitter. Refer to the receiver's instruction manual for frequency change instructions.

ADVANCED FEATURES ON THE PFM T32

Gain Control Adjustment

If necessary, the microphone gain control on the T32 can be increased or decreased to meet the demands of specific listening applications.

Instructions:

1. Open the battery compartment using a coin in the slot in the bottom of the transmitter. Remove the batteries.
2. Lift the battery compartment door up and pull to your left to expose the circuit board.
3. Refer to **FIG 6** to locate the microphone gain control.
4. Using a small screwdriver, turn the gain control fully counterclockwise to *reduce* the gain. Turn the gain control fully clockwise to *increase* the gain.
5. Close the back of the case and battery door.

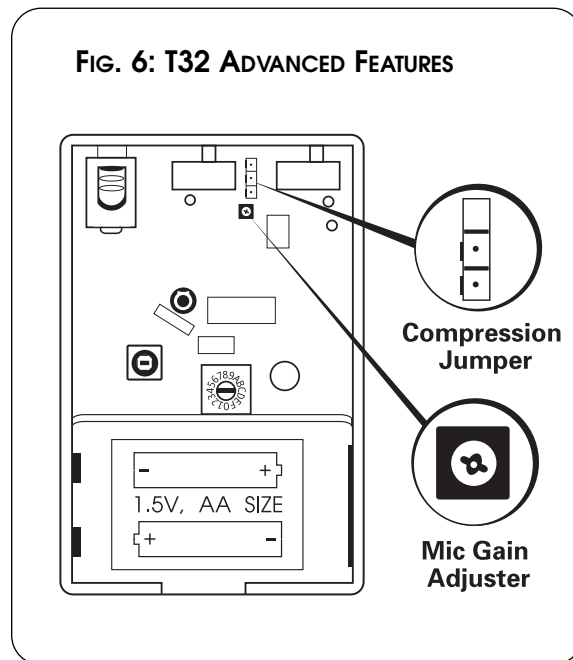

COMPRESSION ADJUSTMENT

By default, the T32 transmitter compression jumper is set to “Off” for normal operation, or 1:1 compression. For hearing assistance applications, the compression jumper can be set to “On” for 2:1 compression.

Instructions:

1. Open the battery compartment using a coin in the slot in the bottom of the transmitter. Remove the batteries.
2. Lift the battery compartment door up and pull to your left to expose the circuit board.
3. Refer to **FIG 6** to locate the Compression Selector.
4. Gently remove the jumper from the circuit board by pulling it up and away from the unit. You will see three exposed “pins.”



To turn compression **“On”** (2:1 Compression): Press jumper on to the **top two** pin locations as shown on left.



To turn compression **“Off”** (1:1 Compression): Press jumper on to the **bottom two** pin locations as shown on left.

5. Close the back of the case and battery door.

USING THE PFM R32 RECEIVER (PFM 300 & PFM 300E RCH):

Receiver model PFM R32 has a single volume control and an earphone output jack.

1. Make sure there are two charged AA batteries in the Receiver. If batteries are not installed, see *Battery Information* on page 13.
2. Plug the earphone or headphone into the “Ear” jack on top of the Receiver.

FIGURE 7: R32 RECEIVER TOP VIEW

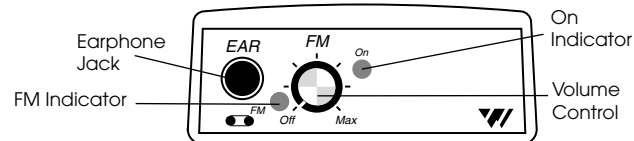

3. Turn the power on by rotating the volume control knob on top of the Receiver.
4. Place the earphone in your ear.
5. Choose the correct channel using the right switch on the R32's back panel.
Unless you have changed the Transmitter channel, set the receiver to channel 1. If the Transmitter is on and tuned to channel 1, the FM Indicator light on the R32 will light.

FIGURE 8: RECEIVER TONE & CHANNEL CONTROLS

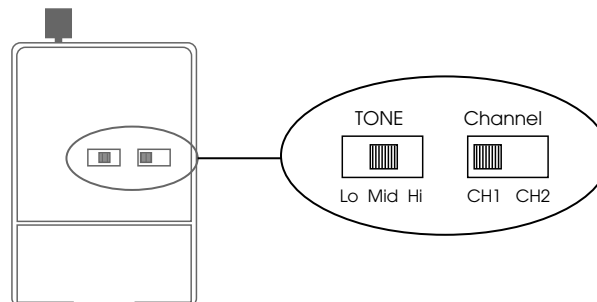

6. Adjust the receiver volume control to a comfortable listening level.
You should be able to hear someone speaking into the Transmitter microphone.
7. Adjust the receiver tone control to your needs. Lo – more low frequencies;
Mid – some low frequency cut; Hi – maximum low frequency cut, emphasizes higher frequencies.
(See Figure 8.)
8. Place the Receiver in the belt clip case provided. The Receiver can be placed in a pants pocket, or clipped onto a belt, harness, or waistband.

Notes:

The earphone cord is the receiving antenna. Do not bunch up the cord or wrap it around the receiver. For best reception, the cord should hang as straight as possible. Make sure the Receiver is turned OFF when not in use. The channel selector can be used to switch between an individual and a group channel.

USING THE PFM R31 RECEIVER (PFM 350 & PFM 350E RCH):

Receiver model PFM R31 has two volume control knobs (one for the FM signal, one for environmental sounds), a microphone input jack, and an earphone output jack.

1. Make sure there are two charged AA batteries in the Receiver. If batteries are not installed, see *Battery Information* on page 13.
2. Insert the small Plug Mount Microphone (MIC 014) into the “Mic” jack on top of the R31 Receiver.

FIGURE 9: R31 TOP VIEW

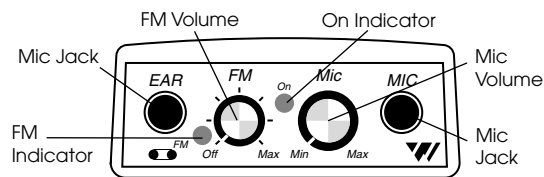

3. Plug the earphone or headphone into the “Ear” jack on top of the Receiver.
4. Turn the power on by rotating the taller “FM” volume control on top of the Receiver.
5. Place the earphone in your ear.

FIGURE 10: RECEIVER TONE & CHANNEL CONTROLS

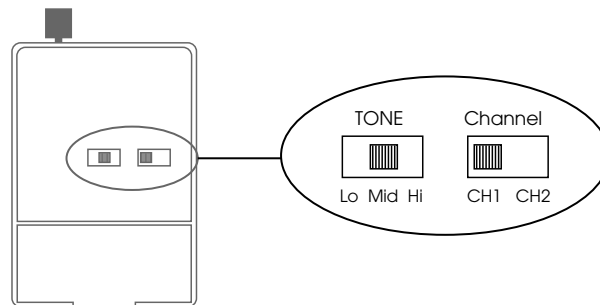

6. Choose the correct channel using the right switch on the R31’s back panel. If the Transmitter is on and tuned to channel 1, the FM Indicator light on the R31 will light.
7. Adjust the receiver tone control to your needs. Lo – more low frequencies; Mid – some low frequency cut; Hi – maximum low frequency cut, emphasizes higher frequencies. (See Figure 10.)
8. Place the Receiver in the belt clip case provided. The Receiver can be placed in a pants pocket, or clipped onto a belt, harness, or waistband.

Notes:

The earphone cord is the receiving antenna. Do not bunch up the cord or wrap it around the receiver. For best reception, the cord should hang as straight as possible. Make sure the Receiver is turned OFF when not in use. The channel selector can be used to switch between an individual and a group channel.

Adjusting The R31 Volume Controls

1. Adjust the taller “FM” volume control to a comfortable listening level. You should be able to hear someone speaking into the Transmitter microphone.
2. Now adjust the shorter “Mic” volume control until you can hear sounds picked up by the environmental microphone on top of the receiver.
3. Adjust the two volume controls for a comfortable mix of FM and environmental sounds.

You will normally want to have the FM signal louder than the environmental Mic signal to avoid picking up extra background noise. If no environmental sounds are desired, turn the “Mic” control fully to “Min”. If you want to hear nearby conversation or your own voice, turn the “Mic” control up.

TUNING THE PFM R32 & R31 RECEIVERS

Tuning for the R32 and R31 Receivers is determined by tuning coils, and is stabilized by phase-locked-loop circuitry. A plastic tuning wrench (PLT 005) is needed to adjust the receiver tuning coil.

1. Use the Transmitter as a tuning signal source. Have someone speak into the microphone so you have something to listen to.
2. Keep the Transmitter and Receiver about 15 - 20 feet apart while tuning. The receiver must be tuned under weak signal conditions.
3. Open the battery compartment using a coin in the slot in the bottom of the transmitter. Pull up the receiver battery flap to open the receiver back like a book. This will expose the circuit board.
4. Move the channel selector switch to channel 2 (right position).
5. Use Figure 11 below to locate the tuning coils. Use the earphone supplied with the receiver to listen for the transmitter signal while you slowly and gently rotate the tuning slugs inside the tuning coil with the tuning wrench. Adjust the tuning coil for channel 2 slowly and carefully. Do not press down on the tuning slug. Adjust for maximum signal.
6. Re-tune all the receivers and mark the new frequency inside the case for future reference.

FIGURE 11: LOCATION OF RECEIVER TUNING COILS

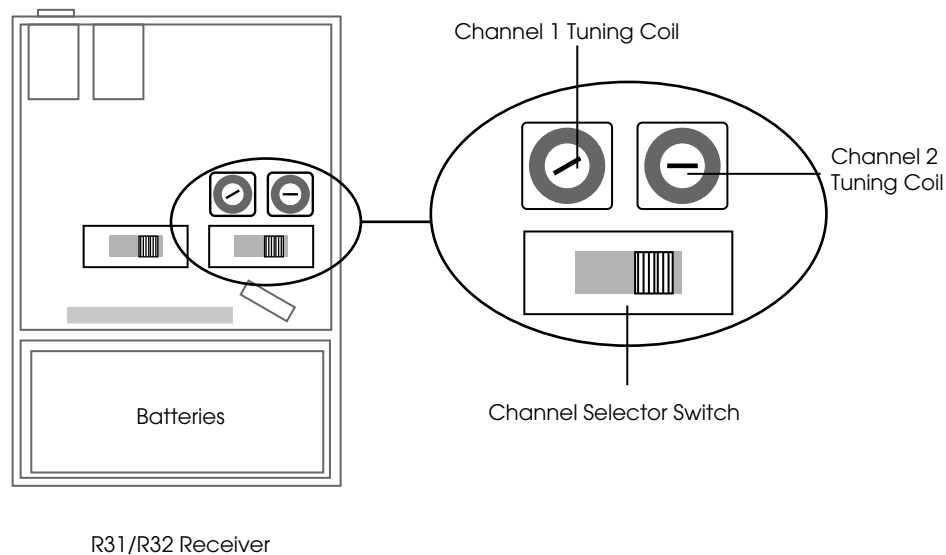

BATTERY INFORMATION

INSTALLATION

Open the battery compartment using a coin in the slot in the bottom of the receiver or transmitter. Press the batteries into place, observing proper battery polarity. Incorrect insertion of the battery is difficult, and if forced, may cause both mechanical and electrical damage to transmitters or receivers not covered by the five year warranty. Units will not work with the battery incorrectly installed.

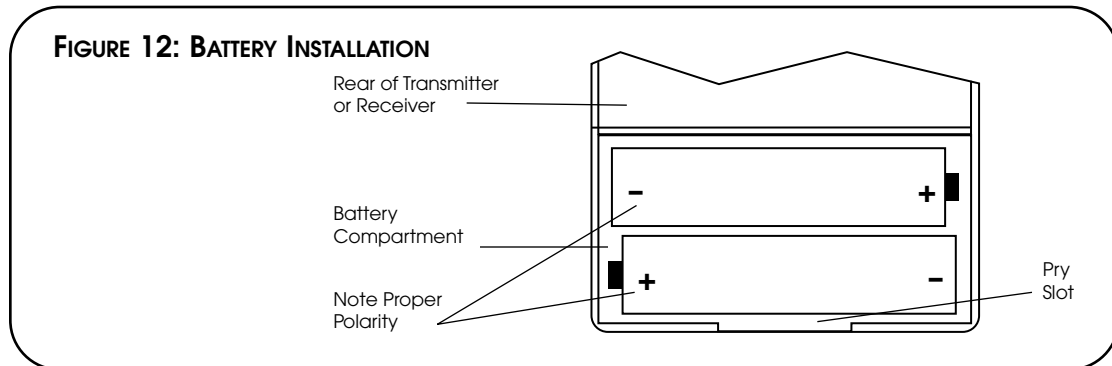

DISPOSABLE BATTERIES

In normal use, two AA 1.5 V alkaline batteries will last about 30 hours in the T32. The batteries will last approximately 80 hours in the R32 and R31 Receivers, respectively.

If the sound becomes weak or distorted, replace the battery. The indicator light may still be on, even with a battery that is weak. Do not leave dead batteries in the receivers! Battery corrosion is not covered by the Williams Sound five year warranty.

RECHARGEABLE BATTERIES

The PFM 350 and PFM 300 Systems can use rechargeable AA batteries (BAT 026). On an overnight charge, these NiMH batteries are designed to operate for 20 hours in a T32 Transmitter. The R32 and R31 Receivers will last for 50 and 60 hours, respectively.

Note: The battery installed in the receiver may be recharged in the receiver only if it is a NiMH battery, and only if the Williams Sound CHG 200A charger is used. Damage from improper charging is not covered by the Williams Sound five year warranty. For charging directions, see figure 13.

!! IMPORTANT WARNINGS !!

DO NOT ATTEMPT TO RECHARGE ZINC CARBON ("HEAVY DUTY"), ALKALINE, OR LITHIUM BATTERIES!

DO NOT ATTEMPT TO RECHARGE DISPOSABLE BATTERIES! These batteries may heat up and explode, causing possible injury and damage to the equipment.

Avoid shorting the plus and minus battery terminals together with metal objects. Battery damage and burns can result!

Use only Williams Sound Supplied chargers and batteries!

FIGURE 13: USING THE OPTIONAL CHG 200A BATTERY CHARGER TO CHARGE TRANSMITTERS AND RECEIVERS

- Step 1: Plug the CHG 200's power supply into the Power Input on the charger's side and a standard AC wall outlet.
- Step 2: Route the power cord around the Cord Hook (see figure at right). This will minimize strain on the cord and jack and insure that the power cord is not detached during charging.
- Step 3: Make sure the receivers/transmitters to be charged are turned OFF.
- Step 4: Place the receivers/transmitters in the slots so that the CHG 200's Charging Pins and receiver's side panel contacts are coupled. Make sure that the charging contact holes line up with the charging pins. The receivers should drop easily into the slots. **DO NOT FORCE THEM IN BACKWARDS.**
- Step 5: The Charging Indicators will light, indicating that charging is in process.
- It takes 14–16 hours to fully charge the batteries. Remove the receivers when charging is completed.

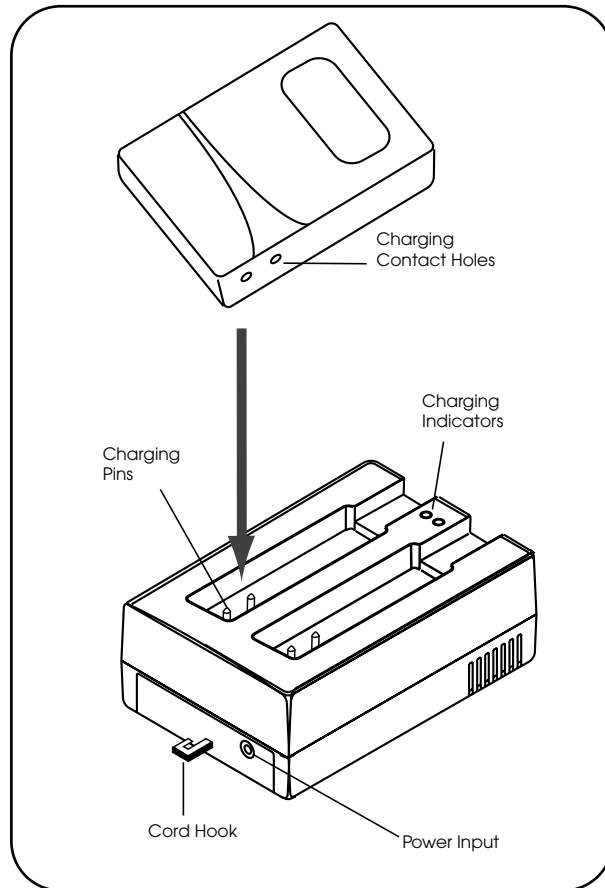

FURTHER SUGGESTIONS

Receivers and Transmitters **SHOULD NOT** be left charging continuously when not in use. Receivers should always be turned OFF while charging.

It's best to allow the batteries to fully discharge before charging.

If the batteries are near end of life and the LED turns off while the receiver is operating, this is an indication to change or recharge your batteries. Approximately one hour of battery life remains.

Repeatedly charging the batteries after short periods of use (1-2 hours) will shorten battery life.

Rechargeable batteries will need to be replaced after 1–2 years of use.

!! WARNING !! **DO NOT ATTEMPT TO RECHARGE DISPOSABLE BATTERIES!**

The batteries may heat up and burst, causing possible injury and damage to the equipment.

Avoid shorting the plus and minus battery terminals together with metal objects. Battery damage and burns can result!

Use only Williams Sound supplied chargers and batteries.

USING YOUR PERSONAL FM SYSTEM WITH A HEARING AID

If you have a hearing aid equipped with a Telecoil (T-Switch), you can use a Neckloop (NKL 003—children’s size, or NKL 001—adult’s size) to magnetically couple the signal from the PFM Receiver into your hearing aid.

The Neckloop plugs into the earphone jack of the receiver. Turn the switch to the “T” position on your hearing aid and adjust the volume control on the receiver to a comfortable level. If you have two hearing aids with telecoils, the signal will couple into both hearing aids (when using a silhouette).

Direct Audio Input cords can be used with compatible hearing aids as well as with Cochlear Implant Processors. If your hearing aid has a direct audio input boot, you can obtain a cord from your hearing aid manufacturer to plug directly into the PFM receiver. The cord should have a 3.5 mm plug.

APPLICATIONS FOR VARIOUS HEARING LOSS LEVELS

The Personal FM is designed to provide hearing assistance for anyone when background noise or distance from the sound source make listening difficult. The microphone and transmitter are placed close to the desired sound source to help minimize background noise and to effectively eliminate the distance between the listener and the sound source. Because hearing ability varies, three categories of amplification have been delineated:

NO HEARING LOSS – LOW AMPLIFICATION

Among Low Amplification applications are classroom and similar uses. The PFM System can be used with headphones or earphones for Central Auditory Processing Disorders, Learning Disabilities, or Attention Deficit Disorders. The PFM System is used primarily to boost speech sounds above other background noises, making it easier for the listener to focus on what is being said. The optional Rugged Headphone (HED 022—children’s size, and HED 021—adult’s size) are recommended for this application. The EAR 013 Single Mini Earphone, EAR 008 Surround Earphone, or EAR 014 Dual Mini Earphone can also be used.

MILD – MODERATE HEARING LOSS

These applications include the classroom, TV listening, car riding, and one-on-one conversations. The PFM System can be used with the Single or Dual Mini Earphone (EAR 013 or EAR 014) for moderate amplification fittings. The PFM System is also suitable for temporary mild hearing loss due to Otitis Media. The Rugged Headphones (HED 021) or Surround Earphone (EAR 022 or EAR 008) are recommended since they do not enter the ear canal.

SEVERE – PROFOUND HEARING LOSS

These applications include the classroom, TV listening, car riding, and one-on-one conversations. For severe to profound hearing loss, the PERSONAL FM System should be used in conjunction with a hearing aid. A Neckloop can be used with hearing aids that have a telecoil. An adaptor cord can be used with hearing aids that have direct audio input

IN CASE OF DIFFICULTY

If your Personal FM System is not working, check the following:

1. Read through the manual and user guide carefully to verify proper setup and installation of your system.
2. Make sure the batteries are fresh or completely charged and that the “plus” and “minus” terminals are installed correctly.
3. If the rechargeable batteries will only work for a short period of time (less than 1 hour) even after they are fully charged, they must be regenerated. Leave them in the receiver or transmitter with the unit turned on, for 5 - 6 hours. Then turn receiver or transmitter off, place it in the charger, and charge for 14 - 16 hours. This should restore normal battery life. Rechargeable batteries will gradually lose their capacity over time and should be replaced every year.
4. Make sure the microphone is plugged into the T32 Transmitter and the earphone is plugged into the Receiver.
5. If you have the PFM System 350, make sure the R31 Receiver’s plug mount microphone IS NOT plugged into the Transmitter.
6. If you’re using the PFM System 350 with the PFM R31 Receiver, make sure that the earphone has been plugged into the earphone jack and not into the R31 Receiver’s microphone jack.
7. Move the Transmitter and Receiver closer together. You may be out of range. When using the system indoors, it’s normal for the signal to momentarily disappear in certain locations. This is called a “drop-out.” Moving a few feet will restore the signal.
8. Make sure that the Transmitter and Receivers are tuned to the same channel. The units have stickers inside the back cover identifying the channel. Unless the Transmitter channel has been changed, set the Receiver to channel 1.
9. Do not try to use more than one Transmitter on the same channel in close proximity to each other. **MORE THAN ONE TRANSMITTER ON THE SAME CHANNEL WILL RESULT IN INTERFERENCE IF THEY ARE CLOSE TOGETHER.** Keep the systems 50 - 100 feet apart or use separate channels for each system used.
10. If you are still hearing interference on the Receivers, turn the Transmitter off and listen with a receiver. If you hear the interference with the Transmitter off, you need to change to a clear channel. See the re-tuning instructions.
11. If problems remain, contact your dealer for further help. Or call Williams Sound toll-free at 1-800-843-3544.

Limited Warranty

Williams Sound products are engineered, designed, and manufactured under carefully controlled conditions to provide you with many years of reliable service. Williams Sound warrants the Hearing Helper® Personal FM System against defects in materials and workmanship for FIVE (5) years. During the first five years from the purchase date, we will promptly repair or replace the Hearing Helper® Personal FM System.

Microphones, earphones, headphones, batteries, chargers, cables, carry cases, and all other accessory products carry a 90-day warranty.

WILLIAMS SOUND HAS NO CONTROL OVER THE CONDITIONS UNDER WHICH THIS PRODUCT IS USED. WILLIAMS SOUND, THEREFORE, DISCLAIMS ALL WARRANTIES NOT SET FORTH ABOVE, BOTH EXPRESS AND IMPLIED, WITH RESPECT TO THE Hearing Helper® Personal FM System, INCLUDING BUT NOT LIMITED TO, ANY IMPLIED WARRANTY OF MERCHANTABILITY OR FITNESS FOR A PARTICULAR PURPOSE. WILLIAMS SOUND SHALL NOT BE LIABLE TO ANY PERSON OR ENTITY FOR ANY MEDICAL EXPENSES OR ANY DIRECT, INCIDENTAL OR CONSEQUENTIAL DAMAGES CAUSED BY ANY USE, DEFECT, FAILURE OR MALFUNCTIONING OF THE PRODUCT, WHETHER A CLAIM FOR SUCH DAMAGES IS BASED UPON WARRANTY, CONTRACT, TORT OR OTHERWISE, THE SOLE REMEDY FOR ANY DEFECT, FAILURE OR MALFUNCTION OF THE PRODUCTS REPLACEMENT OF THE PRODUCT. NO PERSON HAS ANY AUTHORITY TO BIND WILLIAMS SOUND TO ANY REPRESENTATION OR WARRANTY WITH RESPECT TO THE HEARING HELPER® PERSONAL FM SYSTEM. UNAUTHORIZED REPAIRS OR MODIFICATIONS WILL VOID THE WARRANTY.

The exclusions and limitations set out above are not intended to, and should not be construed so as to contravene mandatory provisions of applicable law. If any part or term of this Disclaimer of Warranty is held to be illegal, unenforceable, or in conflict with applicable law by a court of competent jurisdiction, the validity of the remaining portions of this Disclaimer of Warranty shall not be affected, and all rights and obligations shall be construed and enforced as if this Limited Warranty did not contain the particular part or term held to be invalid.

If you experience difficulty with your system, call Toll-Free for customer Assistance:

1-800-843-3544

If it is necessary to return the system for service, your Customer Service Representative will give you a Return Authorization Number (RA) and shipping instruction.

Pack the system carefully and send it to:

Williams Sound Corp.
Attn: Repair Dept.
10321 West 70th Street
Eden Prairie, MN 55344 USA

Your warranty becomes effective the date you purchase your system. Your returned warranty card is our way of knowing when your warranty begins. It also gives us important information about your system including the serial number. This information will help us serve you better in the future. Please take a moment to complete and mail the attached card. Thank you.

TECHNICAL SPECIFICATIONS

FM TRANSMITTER, MODEL PFM T32

Dimensions:	3-5/8" L x 2-3/8" W x 7/8" H (92.1 mm x 60.3 mm x 22.2 mm)
Weight:	4.4 oz (125 g) with battery
Color:	Royal blue, shatter-resistant polypropylene
Battery Type:	Two (2) AA 1.5 V non-rechargeable Alkaline batteries (BAT 001), 70 mA nominal current drain, 30 hours approx. life (OR) Two (2) AA 1.5 V NiMH rechargeable batteries (BAT 026), 70 mA nominal current drain, 20 hours per charge approx., recharges in 14–16 hours, uses CHG 200 or CHG 1600 Charger
Operating Freq's:	Selectable, 16 channels, 72.1 – 75.9 MHz, internal rotary switch
Stability:	± .005%, frequency synthesized, crystal reference, PLL
Modulation:	Wide-band FM, 75 kHz pk, 75 µS pre-emphasis
RF Output:	8000 µV/m at 30 m, max., 40 mW typical
Freq Response:	200 to 10 kHz, + 3 dB at 1% max. THD
Signal-to-Noise Ratio:	55 - 60 dB, with R31 or R32 Receiver
Microphone Gain Control:	45 dB maximum, 18 dB minimum range
Transmit Antenna:	Integral with 39" microphone cord
Microphone:	Electret type, 39" cord, 3.5 mm mono phone plug
Controls:	On/Off switch, slide-type; Microphone Mute Switch, slide-type; Compression Selector 1:1 or 2:1 with internal selectable jumper
Mic Connector:	3.5 mm mono phone jack
Compatible Receivers:	PPA R35, PFM R31, PFM R32
Approvals:	FCC, Industry Canada, RoHS, WEEE
Warranty:	5 years, parts and labor (90 days on accessories)
Note:	FCC regulations, section 15.21, requires the user to comply with the rules of transmitter operation. Any changes or modifications made by the user not expressly approved for compliance may result in the loss of all privileges and authority to operate the equipment.

RECEIVER, MODELS PFM R31 & PFM R32

Dimensions and Weight:	3-5/8" L x 2-3/8" W x 7/8" H (92.1 mm x 60.3 mm x 22.2 mm)
Color:	Royal blue, shatter-resistant polypropylene
Battery Type:	Two (2) AA 1.5 V non-rechargeable Alkaline batteries (BAT 001), 14 mA nom. current drain, 80 hours approx. life (OR) Two (2) AA 1.5 V NiMH rechargeable batteries (BAT 026), 14 mA nominal current drain, 50 hours per charge approx., recharges in 14–16 hours, uses CHG 200 Charger
Operating Freq's:	Pre-Tuned, Field-tuneable, 72 MHz - 76 MHz. Pre-set channels are E (72.9 MHz) and G (75.7 MHz)
FM Deviation:	Wide-band, 75 kHz, 75 µS de-emphasis
AFC Range:	± 120 kHz
Sensitivity:	4 µV at 12 dB Sinad with squelch defeated, squelches at 10 µV for min. 50 dB S/N ratio
Freq Response:	100 to 10 kHz, + 3 dB
Signal–Noise Ratio:	50 dB at 10 uV
Receive Antenna:	Integral with earphone cord
Audio Output:	35 mW, max. at 16 Ω
Output Connector:	3.5 mm mono phone jack
Squelch:	Set to turn off audio under weak or no signal condition
Carrier Detect Ind:	Red LED, turns on in the presence of a carrier
Controls:	Volume: rotary/on/off/volume Tone: 3-way slide switch; Lo = flat response (20 Hz), Mid = –3 dB at 235 Hz, Hi = –3 dB at 730 Hz Channel: 2-way slide switch; Ch 1 = 72.9 MHz, Ch 2 = 75.7 MHz Indicators: On/off and FM
Note:	Specifications are electrical performance
Approvals:	FCC, WEEE
Warranty:	5 years, parts and labor (90 days on accessories)

PFM R31 Receiver Only

Mic Connector:	3.5 mm mono phone jack, supplies positive DC for Williams Sound electret mics
Microphone:	Plug mount electret, omnidirectional, with windscreen, 3.5mm mono phone plug (MIC 014)
Mic Volume:	Rotary control

NOTE: SPECIFICATIONS SUBJECT TO CHANGE WITHOUT NOTICE.

ACOUSTIC SPECIFICATIONS

ANSI 2.44 TEST

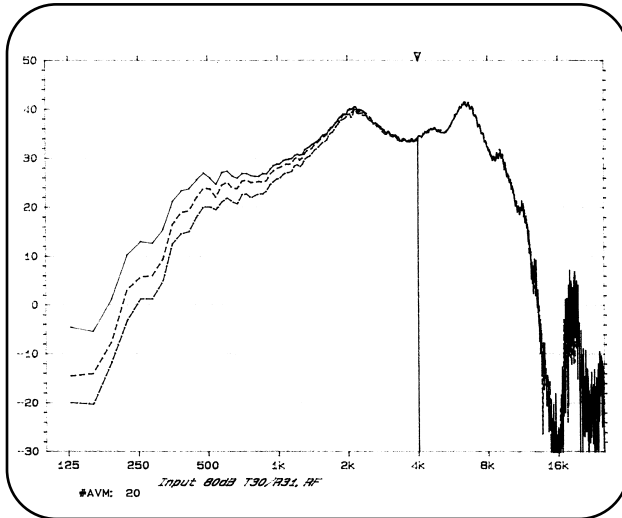

FM Response (PFM R31, R32)

Input: 80 dB random noise
 Device: KEMAR mannequin with BTK 3550 Tester
 Y: 80.0 dB 80 db Main Y: 34.1 dB
 X: 100 Hz + 8 OCT LOG Main X: 4 kHz

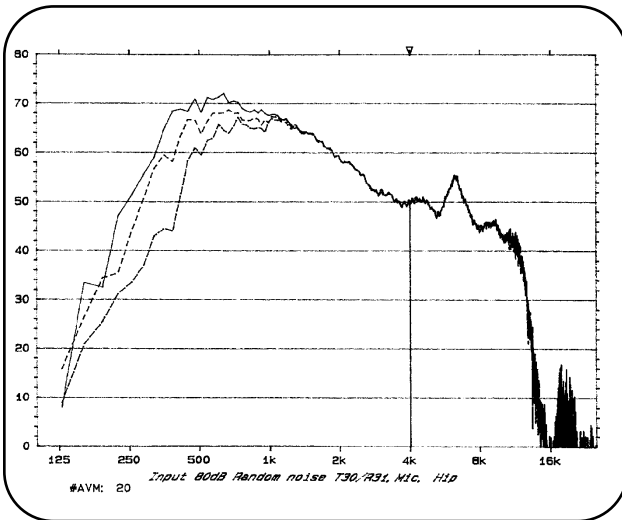

Environmental Mic Response (PFM R31 Only)

Input: 80 dB random noise
 Device: KEMAR mannequin with BTK 3550 Tester
 Y: 80.0 dB 80 db Main Y: 50.2 dB
 X: 100 Hz + 8 OCT LOG Main X: 4 kHz

ANSI S3.22-1987 TEST

FM Response (PFM R31, R32)

MINIMUM LOW CUT (TONE SET TO LOW)

Max. SSPL90: 135.8 dB at 500 Hz
 HF Avg SSPL90: 127.1 dB
 HF Avg Full On Gain: 37.7 dB at 60 dB in
 Reference Test Gain: 38.1 dB
 Response Limit: 80.1 dB F1=200 Hz, F2=8 kHz
 Total Harmonic Dist: 3.6 % at 500 Hz
 3.9 % at 800 Hz
 2.2 % at 1600 Hz

MEDIUM LOW CUT (TONE SET TO MID)

Max. SSPL90: 135.5 dB at 600 Hz
 HF Avg SSPL90: 127.1 dB
 HF Avg Full On Gain: 36.8 dB at 60 dB in
 Reference Test Gain: 37.3 dB
 Response Limit: 79.4 dB F1=200 Hz, F2=8 kHz
 Total Harmonic Dist: 3.4 % at 500 Hz
 3.4 % at 800 Hz
 2.2 % at 1600 Hz

MAXIMUM LOW CUT (TONE SET TO HI)

Max. SSPL90: 133.5 dB at 1000 Hz
 HF Avg SSPL90: 127.0 dB
 HF Avg Full On Gain: 35.4 dB at 60 dB in
 Reference Test Gain: 35.8 dB
 Response Limit: 78.0 dB F1=200 Hz, F2=8 kHz
 Total Harmonic Dist: 1.1 % at 500 Hz
 2.7 % at 800 Hz
 2.1 % at 1600 Hz

Environmental Mic Response (PFM R31 Only)

NO TONE MODIFICATION

Max. SSPL90: 134.8 dB at 500 Hz
 HF Avg SSPL90: 126.4 dB
 HF Avg Full On Gain: 40.9 dB at 60 dB in
 Reference Test Gain: 40.8 dB
 Response Limit: 81.1 dB F1=200 Hz, F2=8 kHz
 Total Harmonic Dist: 1.1 % at 500 Hz
 1.1 % at 800 Hz
 0.3 % at 1600 Hz



WILLIAMS SOUND®

Helping People Hear

10321 West 70th St., Eden Prairie, MN 55344 U.S.A.
800.843.3544 | 952.943.2252 | FAX: 952.943.2174

© 2007, Williams Sound Corp.

MAN 072H